

## Hybrid motor starter - ELR H3-IES-SC- 24DC/500AC-2 - 2900567

Please be informed that the data shown in this PDF Document is generated from our Online Catalog. Please find the complete data in the user's documentation. Our General Terms of Use for Downloads are valid (<http://phoenixcontact.com/download>)



Hybrid motor starter for starting 3~ AC motors up to 500 V AC and 2.4 A output current, with 24 V DC control voltage, adjustable overload shutdown and emergency stop function to SIL 3/PL e and, screw connection.

### Your advantages

- ✓ 22.5 mm wide
- ✓ Safety level according to IEC 61508-1: SIL 3, ISO 13849: PL e
- ✓ Reduction in wiring
- ✓ Long service life
- ✓ Space saving
- ✓ 3-phase loop bridges
- ✓ Adjustable current for bimetal function
- ✓ Low-wear switching



### Key Commercial Data

Packing unit	1 pc
GTIN	 4 046356 526135
GTIN	4046356526135

### Technical data

#### Dimensions

Width	22.5 mm
Height	106.6 mm
Depth	113.7 mm

#### Ambient conditions

Ambient temperature (operation)	-25 °C ... 70 °C (observe derating)
Ambient temperature (storage/transport)	-40 °C ... 80 °C
Degree of protection	IP20

#### Device supply

# Hybrid motor starter - ELR H3-IES-SC- 24DC/500AC-2 - 2900567

## Technical data

### Device supply

Rated control circuit supply voltage $U_s$	24 V DC
Control supply voltage range	19.2 V DC ... 30 V DC
Rated control supply current $I_s$	40 mA
Type of protection	Surge protection
	Reverse polarity protection

### Input data

Input name	Control input
Rated actuating voltage $U_c$	24 V DC
Triggering voltage range	19.2 V DC ... 30 V DC
Rated actuating current $I_c$	5 mA (Input type 1)
Switching threshold	9.6 V ("0" signal)
	19.2 V ("1" signal)
Switching level	< 5 V DC (For EMERGENCY STOP)
Typical turn-off time	< 30 ms
Type of protection	Reverse polarity protection

### Output data load output

Output name	AC output
Rated operating voltage $U_e$	500 V AC
Operating voltage range	42 V AC ... 550 V AC
Rated operating current $I_e$	2.4 A (AC-51)
	2.4 A (AC-53a)
Mains frequency	50/60 Hz
Load current range	180 mA ... 2.4 A (see to derating)
Trigger characteristic in acc. with IEC 60947-4-2	Class 10A
Cooling time	20 min. (for auto reset)
Leakage current	0 mA
Type of protection	Surge protection

### Output data reply output

Output name	Acknowledge output
Note	Confirmation: floating change-over contact, signal contact
Contact type	1 PDT
Switching capacity according to IEC 60947-5-1	3 A (230 V, AC15)
	2 A (24 V, DC13)

### General

Switching frequency	$\leq 2$ Hz (Load-dependent)
Mounting position	vertical (horizontal DIN rail, motor output below)
Mounting type	DIN rail mounting
Assembly instructions	alignable, for spacing see derating
Operating mode	100% operating factor

# Hybrid motor starter - ELR H3-IES-SC- 24DC/500AC-2 - 2900567

## Technical data

### General

Maximum power dissipation	3.3 W
Minimum power dissipation	1.1 W
Operating voltage display	Green LED
Status display	Yellow LED
Indication	Red LED

### Connection data 1

Connection name	Control circuits
Connection method	Screw connection
Stripping length	8 mm
Screw thread	M3
Conductor cross section solid	0.2 mm <sup>2</sup> ... 2.5 mm <sup>2</sup>
Conductor cross section flexible	0.2 mm <sup>2</sup> ... 2.5 mm <sup>2</sup>
Conductor cross section AWG	24 ... 14
Torque	0.5 Nm ... 0.6 Nm

### Connection data 2

Connection name	Load circuit
Connection method	Screw connection
Stripping length	8 mm
Screw thread	M3
Conductor cross section solid	0.2 mm <sup>2</sup> ... 2.5 mm <sup>2</sup>
Conductor cross section flexible	0.2 mm <sup>2</sup> ... 2.5 mm <sup>2</sup>
Conductor cross section AWG	24 ... 14
Torque	0.5 Nm ... 0.6 Nm

### UL data

SCCR	100 kA (500 V AC (fuse: 30 A class CC/30 A class J (high fault))) 5 kA (500 V AC (fuse: 20 A RK5 (standard fault)))
FLA	2.4 A (500 V AC)
Group installation	20 A (class RK5, SCCR 5kA, #24 - 14 AWG max. solid and stranded) 30 A (class CC or J, SCCR 100kA, #24 - 14 AWG max, solid and stranded)
Category code	NLDX

### Insulation characteristics

Rated insulation voltage	500 V
Rated surge voltage	6 kV
Overvoltage category	III
Degree of pollution	2
Designation	Insulation characteristics between the control input and control supply voltage, and auxiliary circuit to the main circuit
Insulation	Safe isolation (IEC 60947-1/EN 50178) at operating voltage ≤ 300 V AC Basic isolation (IEC 60947-1) at operating voltage 300 ... 500 V AC

# Hybrid motor starter - ELR H3-IES-SC- 24DC/500AC-2 - 2900567

## Technical data

### Insulation characteristics

	Safe isolation (EN 50178) at operating voltage 300 ... 500 V AC
Designation	Isolation characteristics between the control input and control supply voltage to auxiliary circuit
Insulation	Safe isolation (IEC 60947-1) in the auxiliary circuit $\leq 300$ V AC
	Safe isolation (EN 50178) in the auxiliary circuit $\leq 300$ V AC

### Standards and Regulations

Designation	Standards/regulations
Standards/regulations	IEC 60947-1
	IEC 60947-4-2
	IEC 61508
	ISO 13849
ATEX	# II (2) G [Ex e] [Ex d] [Ex px]
	# II (2) D [Ex t] [Ex p]

### Approvals/conformities

Safety Integrity Level according to IEC 61508	$\leq 3$ (Safe shutdown)
	2 (Motor protection)
Category acc. to EN ISO 13849	$\leq 3$ (Safe shutdown)
Performance level according to ISO 13849	$\leq e$ (Safe shutdown)
ATEX	# II (2) G [Ex e] [Ex d] [Ex px]
	# II (2) D [Ex t] [Ex p]
EU-type examination certificate	PTB 07 ATEX 3145
UL certificate	NLDX.E228652

### Environmental Product Compliance

China RoHS	Environmentally Friendly Use Period = 50
	For details about hazardous substances go to tab "Downloads", Category "Manufacturer's declaration"

## Drawings

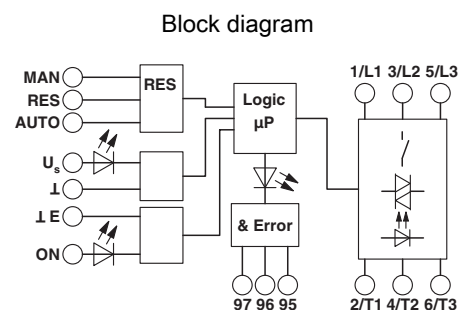
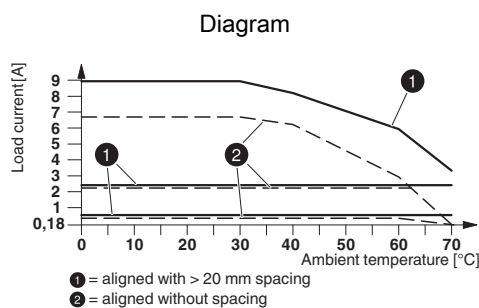

### Derating diagram

# Hybrid motor starter - ELR H3-IES-SC- 24DC/500AC-2 - 2900567

Circuit diagram

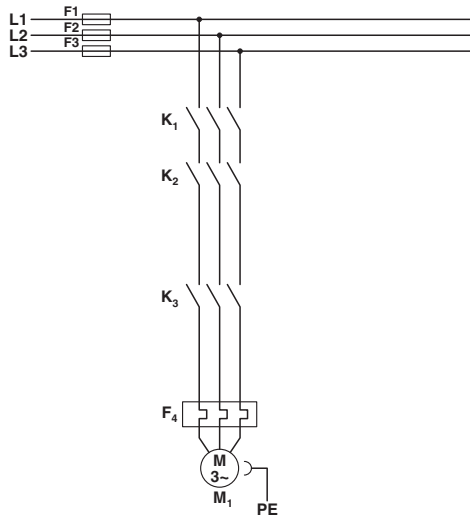

Conventional structure  
Main current path for contactor according to category 3

- K1 + K2 = Emergency stop contactor
- K3 = Right contactor
- F4 = Motor protection relay

Circuit diagram

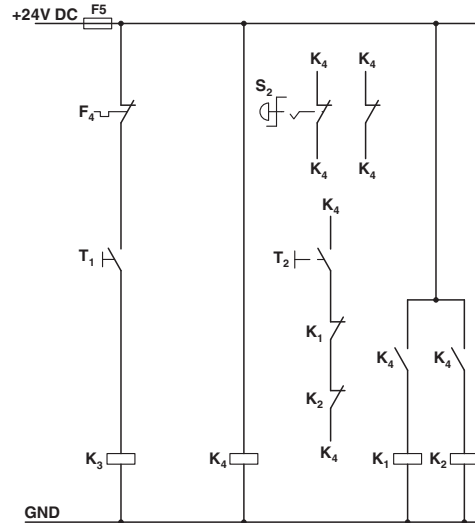

Conventional structure  
Control current path for contactor according to category 3

- K1 + K2 = Emergency stop contactor
- K3 = Right contactor
- K4 = PSR SCP-24DC.../safety relay
- T1 = Right, T3 = Reset
- S2 = Emergency stop
- F4 = Motor protection relay

Circuit diagram

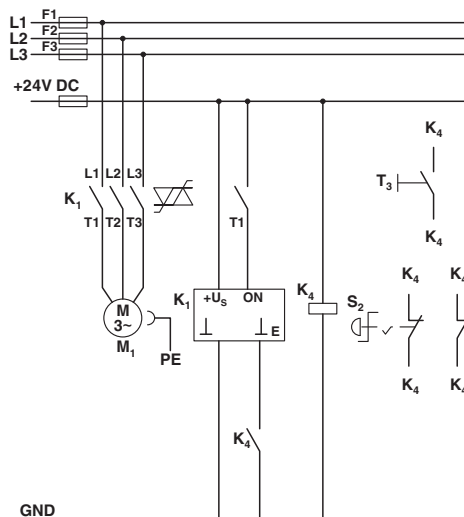

Structure with CONTACTRON  
Main and control current path for '3 in 1' hybrid motor starter according to category 3

- K1 = '3 in 1' hybrid motor starter
- K4 = PSR SCP-24DC.../safety relay

# Hybrid motor starter - ELR H3-IES-SC- 24DC/500AC-2 - 2900567

T1 = Right, T3 = Reset  
S2 = Emergency stop

## Approvals

### Approvals

---

#### Approvals

UL Listed / cUL Listed / GL / GL-SW / UL Listed / IECCEB Scheme / cUL Listed / CCC / EAC / GL

---

#### Ex Approvals

ATEX

---

### Approval details

UL Listed		<a href="http://database.ul.com/cgi-bin/XYV/template/LISEXT/1FRAME/index.htm">http://database.ul.com/cgi-bin/XYV/template/LISEXT/1FRAME/index.htm</a>	FILE E 228652
-----------	--	---	---------------

cUL Listed		<a href="http://database.ul.com/cgi-bin/XYV/template/LISEXT/1FRAME/index.htm">http://database.ul.com/cgi-bin/XYV/template/LISEXT/1FRAME/index.htm</a>	FILE E 228652
------------	--	---	---------------

GL		<a href="http://exchange.dnv.com/tari/">http://exchange.dnv.com/tari/</a>	54757-08 HH
----	--	---	-------------

GL-SW			54757-08 HH
-------	--	--	-------------

UL Listed		<a href="http://database.ul.com/cgi-bin/XYV/template/LISEXT/1FRAME/index.htm">http://database.ul.com/cgi-bin/XYV/template/LISEXT/1FRAME/index.htm</a>	FILE E 323771
-----------	--	---	---------------

IECEEB Scheme		<a href="http://www.iecee.org/">http://www.iecee.org/</a>	DE1-55728
---------------	--	---	-----------

cUL Listed		<a href="http://database.ul.com/cgi-bin/XYV/template/LISEXT/1FRAME/index.htm">http://database.ul.com/cgi-bin/XYV/template/LISEXT/1FRAME/index.htm</a>	FILE E 323771
------------	--	---	---------------

CCC			2016010304871315
-----	--	--	------------------

## Hybrid motor starter - ELR H3-IES-SC- 24DC/500AC-2 - 2900567

### Approvals



Phoenix Contact 2019 © - all rights reserved  
<http://www.phoenixcontact.com>

PHOENIX CONTACT GmbH & Co. KG  
Flachsmarktstr. 8  
32825 Blomberg  
Germany  
Tel. +49 5235 300  
Fax +49 5235 3 41200  
<http://www.phoenixcontact.com>